

Regular Paper

Flow Characteristics of Pressure Reducing Valve with Radial Slit Structure for Low Noise

Youn, C.*¹, Asano, S.*², Kawashima, K.*¹ and Kagawa, T.*¹

*1 Precision and Intelligence Laboratory, Tokyo Institute of Technology, R2-45, 4259 Nagatuta, Midori-Ku, Yokohama, 226-8503, Japan. E-mail: youn.c.aa@m.titech.ac.jp

*2 Department of Civil and Environmental Engineering, Tokyo Institute of Technology, M1-1, 2-12-1, O-okayama, Meguro-ku, Tokyo, 152-8552, Japan. E-mail: asano.s.aa@m.titech.ac.jp

Received 27 November 2007
Revised 4 August 2008

Abstract: Pressure reducing valves are widely used to maintain the pressure of gas reservoirs to specific values. In a normal valve, supply pressure is decompressed with an orifice structure. When compressed air passes through the orifice structure, considerable noise occurs at the downstream side. In this paper, we have developed a radial slit structure that can reduce pressure without noise. The noise is reduced by changing the orifice structure into the radial slit structure. The radial slit structure valve reduces pressure without noise by suppressing the generation of turbulence and shock wave at the downstream. The analysis of the flow in radial slit structure was achieved by CFD2000 software. The flow rate and pressure distribution were simulated and compared with the experimental result. To confirm the generation of shock wave, the flow of orifice and radial slit structure at the downstream was visualized by Schlieren photography method. A shock wave was generated in the orifice structure, but no shock wave was generated in the radial slit structure. Noise reduction efficiency was investigated by the experiment. The experiment apparatus was set up to JIS standards. The experimental results indicated that the noise level decreased by approximately 40 dB in the slit structure. It is confirmed that the radial slit structure has effectiveness for low noise in the pressure reducing flow. And, it is expected that it can be applied to various kinds of industrial fields.

Keywords: Pneumatics, Radial Slit Structure valve, Schlieren, Shock Wave, Noise.

1. Nomenclature

| | | |
|--------|----------------------|----------------------|
| h | Height of slit | [μm] |
| P | Pressure | [Pa(abs)] |
| P_s | Supply Pressure | [Pa(abs)] |
| Q | Volume flow rate | [l/min normal] |
| r | Radial direction | [m] |
| R_o | Gas constant | [J/kg·K] |
| SPL | Sound pressure level | [dB(A)] |
| u | Velocity | [m/s] |
| T | Temperature | [K] |
| ρ | Density | [kg/m ³] |
| ξ | Inlet loss | |

2. Introduction

Pneumatic systems are widely used in industrial fields from the viewpoint of low cost and safety. A pressure reducing valve is used to maintain the pressure of gas reservoirs to specific values as shown in Fig. 1. In a normal valve, supply pressure is depressurized with an orifice structure. When pressurized air passes through an orifice structure, considerable noise and pressure fluctuation occur at the downstream. Therefore, reduction of noise originating from the valve is required in industrial fields.

These phenomena have been investigated both analytically and experimentally (Lighthill, 1952; Reethof, 1988). In addition, several methods, such as the use of diffusers (Boger, 1971), wrapping pipe with sound damping materials (Bell, 1993), changing the plug structure (Amini et al., 1995), and the use of porous materials (N. Atalla et al., 2001) and silencers (Davies et al., 1997) have been developed to reduce noise. However, in these methods, the orifice structure was used to reduce the pressure. When the flow rate increases, the flow might become turbulence. In some cases, sonic flow occurs even when the pressure ratio is lower than 0.528. Turbulent and sonic flow can generate considerable noise and shock waves.

In this paper, we have developed a radial slit structure valve that can reduce noise in the pressure reducing process. The noise is reduced by changing the orifice structure into the radial slit structure. The radial slit structure reduces the noise by suppressing the generation of turbulence and shock wave at the downstream. The newly developed slit structure is contained in Sec. 2, and the numerical analysis method is contained in Sec. 3. The flow characteristics and pressures distribution of the slit structure are simulated and compared with the experimental result in Sec. 4. The visualization of the shock wave at the outlet of the orifice structure and slit structure is investigated by the Schlieren photography method in Sec. 5. Finally, the effect of the noise reduction of the slit structure is investigated experimentally.

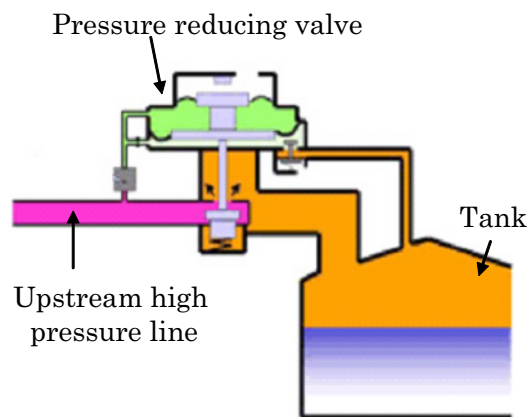

Fig. 1. Pressure reducing valve in pneumatic systems.

3. Newly Developed Radial Slit Structure

Figure 2 shows a schematic drawing of the newly developed radial slit structure. The slit structure consists of three elements, an upper disk, a slit disk and a lower disk. The disks have four holes and are fixed by bolts. The upper disk consists of the flow inlet. The top view of the slit disk is shown in Fig. 3. The red part is milled about micrometer order by machining and it makes the radial slit flow. The lower disk consists of a lower surface of the radial slit flow.

The compressed air enters from the center of the upper disk and is exhausted outward through the radial slits to the down stream. When the fluid flows through the slit, the fluid is decompressed in the slit because of the viscous resistance of fluid. A shock wave caused by a sudden pressure change does not occur in the downstream.

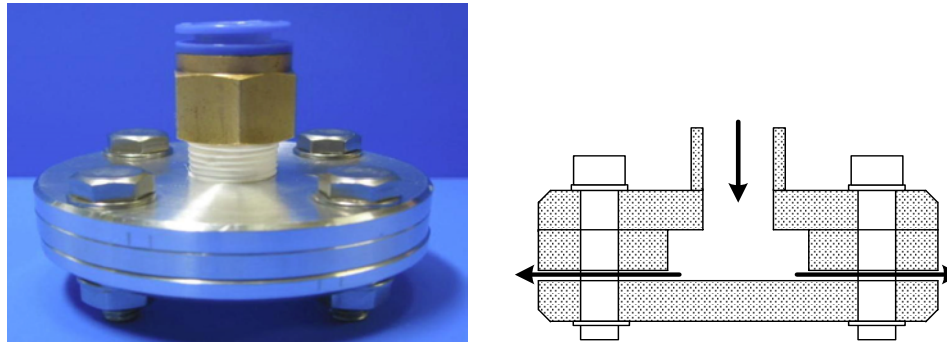

Fig. 2. Newly developed radial slit structure.

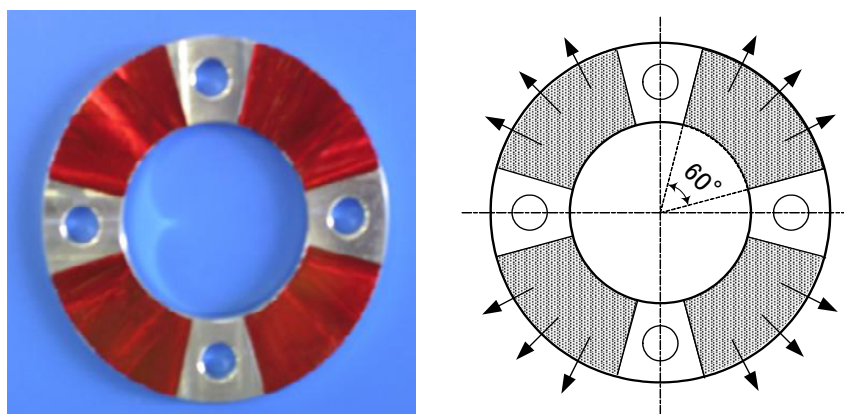

Fig. 3. Top view of the slit disk.

4. Numerical analysis

The analysis is achieved by CFD2000 simulation software. CFD2000 is the outstanding general purpose calculation hydrodynamics code which uses the FVM (Finite Volume Method). The governing equations are as follows. The conservation of mass, momentum, energy and state equations are expressed by Eqs. (1), (2), (3) and (4).

$$\frac{\partial(\rho u_i)}{\partial x_i} = 0 \tag{1}$$

$$\frac{\partial(\rho u_i u_j)}{\partial x_i} = \frac{\partial \tau_{ij}}{\partial x_i} - \frac{\partial p}{\partial x_i} \tag{2}$$

where,

$$\tau_{ij} = \left[\mu \left(\frac{\partial u_i}{\partial x_j} + \frac{\partial u_j}{\partial x_i} \right) - \frac{2}{3} \mu \frac{\partial u_k}{\partial x_k} \delta_{ij} \right]$$

$$\frac{\partial(\rho u_i H)}{\partial x_i} = \frac{\partial}{\partial x_i} \left[\frac{\lambda}{C} \frac{\partial H}{\partial x_i} \right] + u_i \frac{\partial p}{\partial x_i} + \left[\mu \left(\frac{\partial u_i}{\partial x_j} + \frac{\partial u_j}{\partial x_i} \right) - \frac{2}{3} \mu \frac{\partial u_k}{\partial x_k} \delta_{ij} \right] \frac{\partial u_i}{\partial x_j} \tag{3}$$

$$p = \rho R_o T \tag{4}$$

The 2-dimensional mode of cylinder coordinates type is used because it is radial flow. The flow is assumed to be laminar flow. Compressibility and heat transfer are taken into consideration. The operation fluid is air. The boundary conditions are like this. The flow velocity of the top and bottom wall is zero and temperature is 293 K. The inlet condition is that velocity to the radial direction is constant and temperature is 293 K. The outlet condition is that velocity to the vertical direction is zero and pressure is atmospheric pressure. The number of grid of radial directions is 100, and vertical direction is 20. One part of the computational grid is shown in Fig. 4.

The extra pressure drop p_i with sudden change of area must be considered in the entrance region (Stone, 1994). This is evaluated using the following equation

$$\Delta p_i = \xi \frac{\rho u_{in}^2}{2} \quad (5)$$

where ξ is the coefficient of the inlet loss, whose value 0.5 was chosen to approximately match the experimental results. As a result, the supply pressure p_s is given by adding the losses in the slit and the losses associated with the inlet region.

$$p_s = p_m (\text{From simulation}) + \Delta p_i \quad (6)$$



Fig. 4. One part of computational grid.

5. Characteristics of the Slit Structure

5.1 Flow Characteristics

The flow characteristics of the radial slit structure were investigated by simulation and experiment. The size of the radial slit structure is as follows. The inner diameter is 0.032 m, outer diameter is 0.06 m and height of slit that is milled by machining is 47 μm . There are four channels on the slit disk with an angle of 60° as shown in Fig. 3. It is assumed that the total flow angle of the slit is 240°. The characteristics were calculated by using those parameters.

The flow characteristics were measured experimentally. The supply pressure was controlled by the pressure regulator from 100 kPa to 400 kPa. The pressure and flow rate were measured using a pressure gauge (Nagano Keiki Co., Ltd., AA10-121) with uncertainty of 0.5% and a flow meter with uncertainty of 2 %.

The flow characteristics are shown in Fig. 5. The dashed and the solid line show the simulation results of CFD2000 and the calculated results of Eq. (6), respectively. The square marks show the experimental results. The results clarify that the experimental and calculated

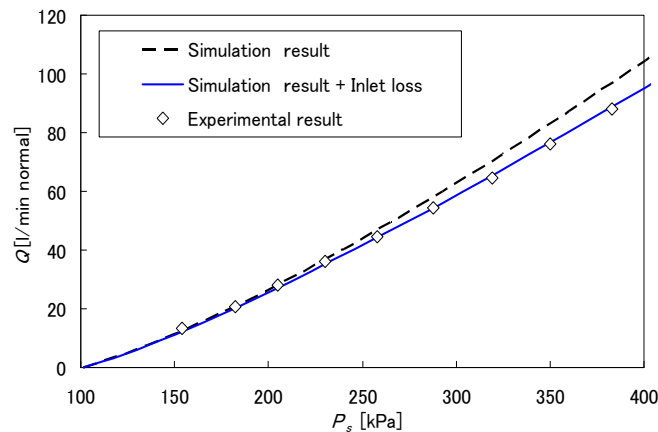

Fig. 5. Flow rate characteristics of the radial slit structure.

results were in agreement. The influence of pressure loss in the entrance region was small within the supply pressure 250 kPa. However, the influence becomes large, when the supply pressure rises above it. In addition, the relation between pressure and flow rate was almost linear, and it was different from that of the orifice structure. In the orifice structure, the flow characteristic is root curve up to the choked flow. When the pressure is above the choked pressure, the flow becomes sonic flow. In the sonic flow, the flow characteristic becomes linear and the function of the supply pressure. But, as for the radial slit, when supply pressure was 400 kPa, mean velocity of the exit was 243 m/s in the simulation result, the flow was subsonic speed. Moreover, when the representative length is assumed to be twice the slit height, Reynolds number of the slit exit is 1462. Because the height of slit is so narrow, Reynolds number was very small despite high velocity in the exit.

5.2 Pressure Distribution

The pressure distribution of the radial slit structure was investigated by simulation and experiment. The results are shown in Fig. 6. To measure pressure distribution of radial slit structure in the experiment, a hole of 0.5 mm in diameter was made in six places. The supply pressure was adjusted to 200 kPa and 400 kPa, and the downstream pressure was set to atmospheric pressure. The solid line shows the results calculated by Eq. (6). The square and circle marks show the experimental results. The results clarify that the experimental and calculated results were in agreement. When the supply pressure was 200 kPa, the pressure loss was almost linear. When the supply pressure was 400 kPa, the pressure loss between the entrance and the exit region was very large. Decompression was done in the radial slit structure even if supply pressure was 400 kPa. Then, it is thought that noise caused by pressure fluctuation becomes small in the downstream of the radial slit structure.

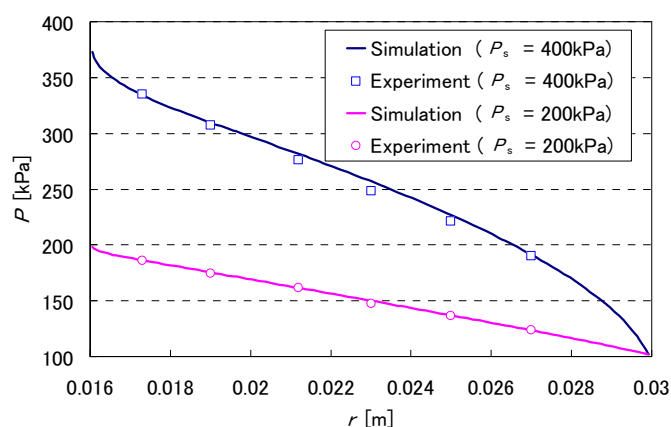

Fig. 6. Pressure distribution along radial direction.

6. Visualization by Schlieren Photography Method

The Schlieren photography method is a technique of making visible the density difference of the gas and liquid. The generation of the shock wave at the downstream of the radial slit and the orifice structure was visualized using the Schlieren photography method. In this research, the compact unit of SLC-100, Mizojiri Optical Cop. was used. This Schlieren photography device consisted of a light source box, two Schlieren lenses, object (radial slit and orifice structure), knife edge and camera.

Figure 7 and 8 show the generation of the shock wave at the downstream of the orifice structure and radial slit structure. The downstream of the orifice structure is shown in Fig. 7. Figure 7(a) shows the result of the supply pressure 180 kPa and Fig. 7(b) shows the result of 400 kPa. The diameter 1.8 mm of the orifice structure was used. Generally, when the pressure ratio between the upstream side and the downstream side is 0.528 or less, a shock wave is generated. As shown in Fig. 7(a), a shock wave was not generated at the orifice structure downstream, because the experiments were done under pressure ratio of 0.562. In this case, the noise would be generated by the turbulent flow. In Fig. 7(b), a shock wave was generated, because the experiments were done under a pressure ratio of 0.253. There was a sudden change of the pressure in the shock wave, and it became the

source of broadband noise and screech tone noise. The results show that a high noise level would occur at the down stream of the orifice structure because of the turbulent flow and shock wave.

The downstream of the radial slit structure is shown in Fig. 8 with the supply pressure 400 kPa. Figure 8(a) shows the side view and Fig. 8(b) shows the top view of the radial slit structure. The results show that the shock wave was not generated at the radial slit structure downstream. The shock wave was not generated despite the supply pressure 400 kPa whose pressure ratio is 0.25. It is thought that the reason for this is that the high compressed air is decompressed in the radial slit structure. And, the decompression with low noise is expected with the supply pressure that is higher than 400 kPa.

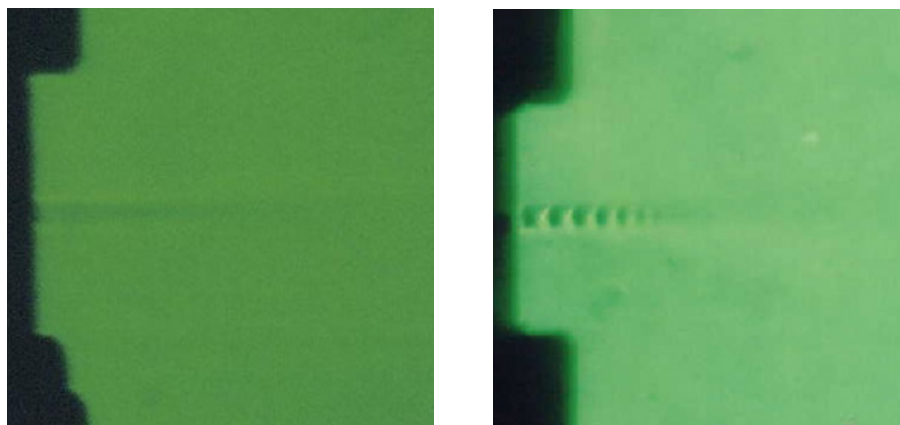

(a) $P_s = 180$ kPa, diameter = 1.8 mm (b) $P_s = 400$ kPa, diameter = 1.8 mm

Fig. 7. Schlieren photograph of the orifice structure.

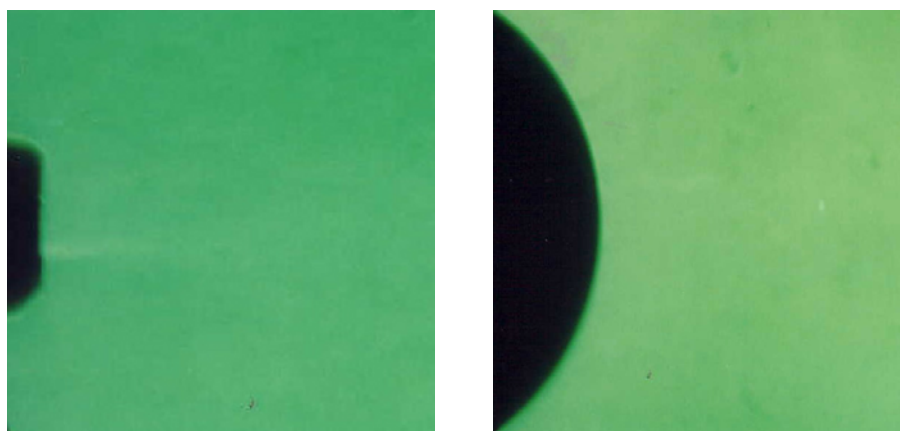

(a) Side view

(b) Top view

Fig. 8. Schlieren photograph of the radial slit structure, $P_s = 400$ kPa.

7. Noise Level

The noise level of the radial slit and orifice structure were measured, according to the Japanese Industrial Standards exhaust sound reducing characteristics (JIS B8379, 1995). The room was covered with acoustic material in order to maintain a background noise level of 30 dB. Orifice structure and the radial slit were installed in the end of the pipe of diameter 8mm. The buffer tank was installed at the upsteam side of the pipe and pressure of it was regulated to maintain a constant pressure. The condenser microphone was placed in the room at an angle of 45° from the center axis of the valve. The distance from the valve to the microphone was 1.0 m. The noise level was measured by the microphone and sound level meter. In addition, we used the A-weighted sound pressure levels

because this study is about the environmental noise in factories.

The radial slit and orifice structure did not have the same flow characteristics in all pressure range. To compare noise level in the region where the flow characteristic was the same, six kinds of orifices whose respective diameters were different were prepared. The diameter of orifice 1.2 mm at 180 kPa, 1.4 mm at 210 kPa, 1.5 mm at 250 kPa, 1.6 mm at 290 kPa, 1.7 mm at 350 kPa and 1.8 mm at 400 kPa were used. The experimental results are shown in Fig. 9. The noise level of the radial slit structure was almost near the background noise up to supply pressure 250 kPa. In the case of 180 kPa, the noise of orifice structure was generated by merely turbulent flow. It was larger than that of the radial slit by about 30dB. In the case of 400 kPa, the noise of the orifice structure was generated by turbulent flow and shock wave. It was larger than that of the radial slit by about 40dB.

Also, the sound pressure spectra of orifice structure and radial slit structure are shown in Fig.10. The sound pressure levels were non-weighted sound pressure levels. The triangle marks show the choked flow of the orifice structure. The circle marks show the levels before the choke flow of the orifice structure. The square marks show the radial slit structure. The radial slit structure had a large effect on noise reduction at high frequency. It was thought that the radial slit structure had a noise reduction effect by suppressing the generation of turbulence and shock wave at the downstream.

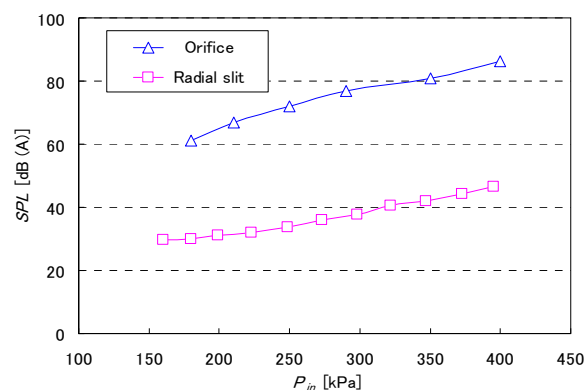

Fig. 9. Noise level of orifice structure and radial slit structure.

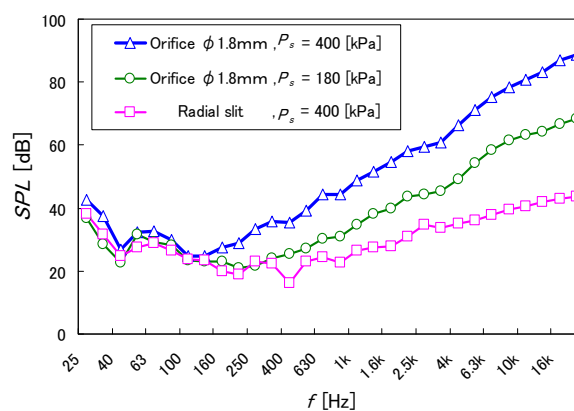

Fig. 10. Sound pressure spectra of orifice structure and radial slit structure.

8. Conclusion

In this paper, we have developed a radial slit structure valve that can reduce pressure with low noise. The radial slit structure has the 47 μm height of slit to reduce noise by suppressing the generation of turbulence and shock wave at the downstream. The flow rate and pressure distribution were simulated and compared with the experimental results. The result shows that decompression occurs in the radial slit structure even if the supply pressure is 400 kPa. The generation of shock wave was investigated by the Schlieren photography method, and a shock wave was not generated in the radial slit structure. Compressible fluid expands smoothly in the proposed radial slit structure. The noise

level and the sound pressure spectra of the radial slit structure were compared with the orifice structure. The experimental results indicated that the noise level decreased by approximately 40 dB in the slit structure at 400 kPa. And, the radial slit structure had a large effect of noise decrease at high frequencies. The results verified the effectiveness of radial slit structure for low noise in the pressure reducing flow.

References

- Amini, A. and Owen, I., A Practical Solution to the Problem of Noise and Fluctuation in a Pressure-Reducing Valve, *Exp. Therm. Fluid Sci.*, 10 (1995), 136-141.
- Atalla, N. and Panneton, R., Acoustic absorption of macro-perforated porous materials, *J. Sound and Vibration*, 243-4 (2001), 659-678.
- Bell, L. H., Industrial Noise Control, *Mech. Eng. (Am. Soc. Mech. Eng.)*, 88 (1993), 417-426.
- Davies, P. O. L. A., Harrison, M. F. and Collins, H. J., Acoustic Modeling of Multiple Path with Experimental Validations, *J. Sound Vib.*, 200-2 (1997), 195-225.
- Huang, C., Gregory, J. W. and Sullivan, J. P., Flow Visualization and Pressure Measurement in Micronozzles, *Journal of Visualization*, 10-3 (2006), 281-288.
- JIS B8379, The pneumatic silencer, (1995), 653-657 (in Japanese).
- Lighthill, M. J., On Sound Generated Aerodynamically 1, General Theory, *Proc. R. Soc. London, Ser. A*, 211 (1952), 564-587.
- Reethof, G., A Theoretically Based Valve Noise Prediction Method for Compressible Fluids, *ASME J. Vib., Acoust., Stress, Reliab. Des.*, 108 (1988), 329-338.
- Reungoat, D., Rivière, N. and Fauré, J. P., 3C PIV and PLIF Measurement in Turbulent Mixing, Round Jet Impingement, *Journal of Visualization*, 10-1 (2006), 99-110.
- Stone, C. R. and Wright, S. D., Nonlinear and Unsteady Flow Analysis of Flow in a Viscous Flowmeter, *Trans. Inst. Meas. Control*, 16-3 (1994), 128-141, London.

Author Profile



Chongho Youn: Born in March 1973. Received his master degrees in Mechanical Engineering from Chonnam National University (Korea) in 1999. Received his Ph. D degree from the Tokyo Institute of Technology (Japan) in 2005. He was working as an assistant professor at the Precision and Intelligence Laboratory of this institute. His primary research interests are fluid measurement control and visualization.

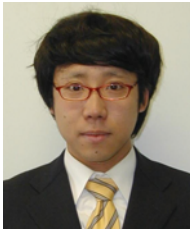

Seiichiro Asano: Born in September 1979. Received his M.Sc degree from the Tokyo Institute of Technology in Japan. He was a PhD student in the civil engineering course.



Kenji Kawashima: Born in July 1968. Received his Ph. D degree from the Tokyo Institute of Technology (Japan) in 1997. He was working as an associate professor at the Precision and Intelligence Laboratory of this institute. His primary research interests are fluid measurement and control, robot engineering.



Toshiharu Kagawa: Born in November 1950. Received his M. Sc and Ph. D degree from the Tokyo Institute of Technology in Japan. He was working as a professor at the Precision and Intelligence Laboratory of this institute. His primary research interests are pneumatics, fluid measurement and control.